

# XCT12L4\_1汽车起重机 / Truck Crane

## 技术规格书

Technical specifications

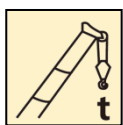

16 t

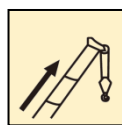

31.5 m

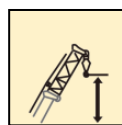

39 m



2020年03月02版

# 目录

## Content

目录	
Content	
尺寸参数 Dimensions	3
技术规格 Product Specifications	4-7
重量/作业速度 Weight / Working speeds	8
臂架组合方案 Boom / Jib combinations	9
主臂/副臂 Boom/Jib	10-12
符号标识 Description of symbols	13
主要技术参数表 Transportation plan	14-15
注意事项 Notes	17

# 尺寸参数 Dimensions

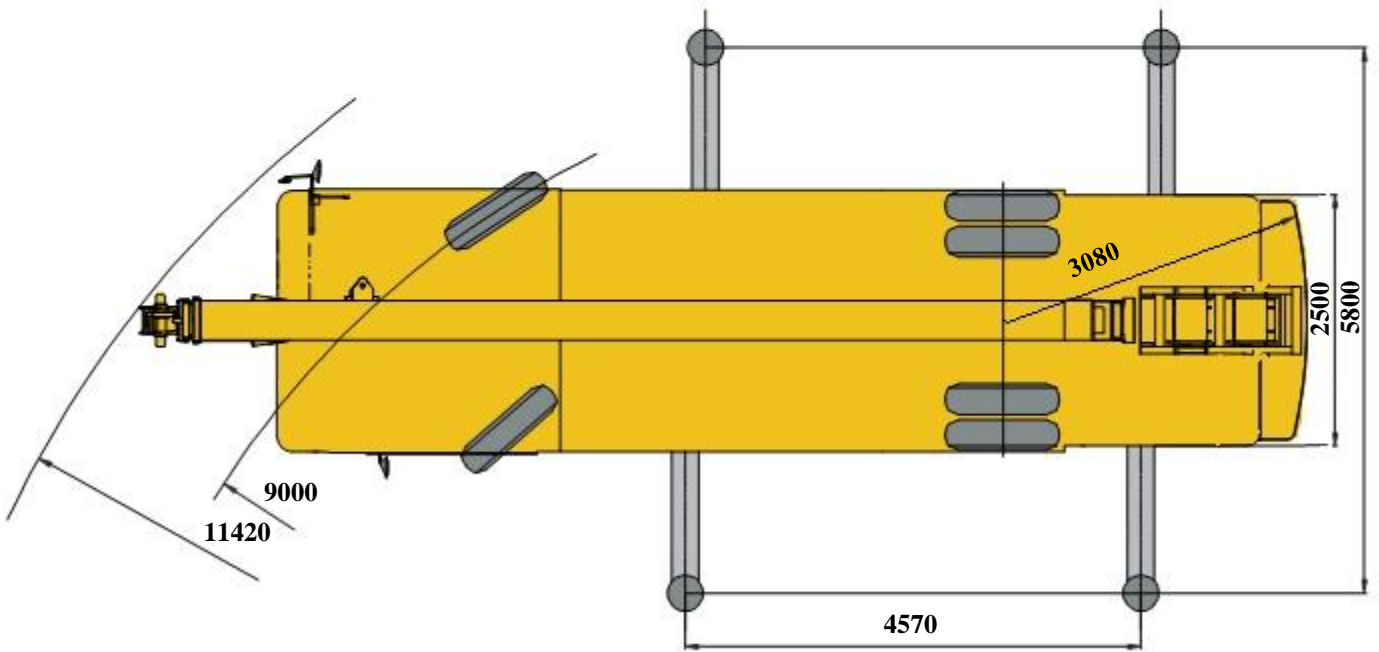
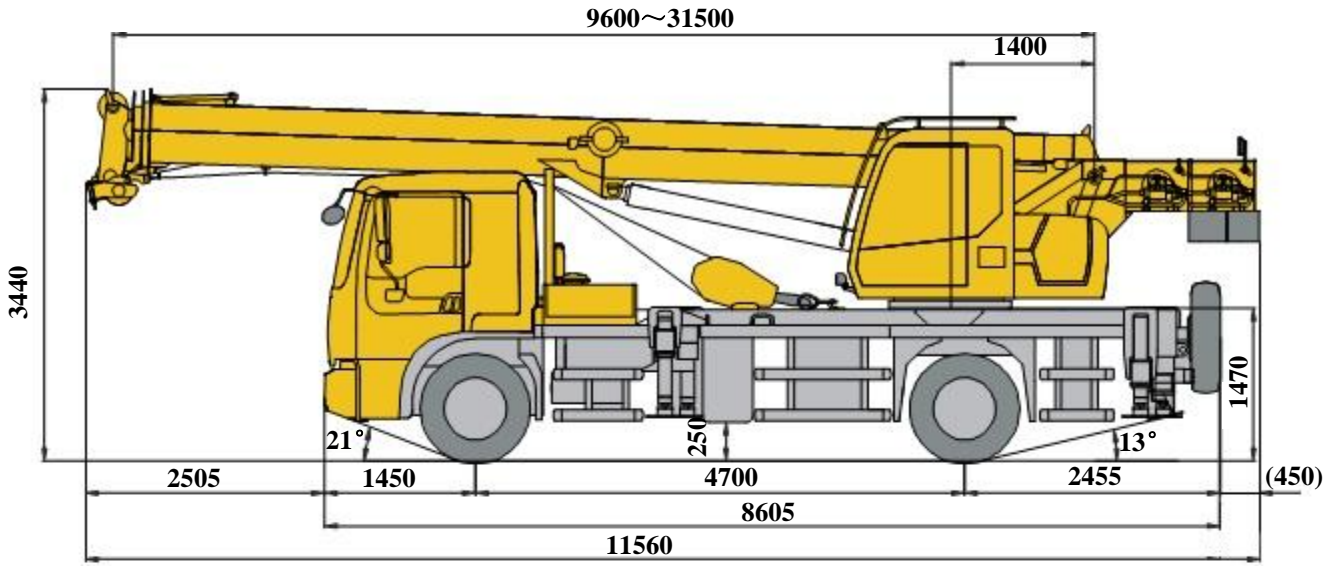

# 技术规格

## Technical specifications

	底盘	配置
车架	徐工设计、制造，全覆盖式走台板，防扭转箱型结构，高强度钢材制造。	●
支腿	H型水平支腿结构，4点支撑，全液压操纵，操纵控制台安装在底盘两侧，控制台装水平仪用于调平起重机。支腿的支脚用球铰装置收存垂直支腿下。支腿设计用于抬起整个起重机身以使起重机在各种工况条件更好地作业。 支脚盘尺寸：φ350mm 最大起重量时支腿反力：189KN	●
发动机	WP6.220E50，直列六缸增压中冷水冷高压共轨压燃式柴油发动机，潍柴制造，额定功率162/2300，最大扭矩850/（1200-1600）rpm，国V排放标准。 燃油箱容积：200L。	●
	SC7H230Q5，直列六缸增压中冷水冷高压共轨压燃式柴油发动机，上柴制造，额定功率170kW/2300rpm，最大扭矩900Nm/（1200-1600）rpm，国V排放标准。	○
	SC7H230Q6，直列六缸增压中冷水冷高压共轨压燃式柴油发动机，上柴制造，额定功率170kW/2300rpm，最大扭矩900Nm/（1100~1700）rpm，国VI排放标准。	○
变速箱	陕齿机械全同步器变速箱，8个前进挡，2个倒档	●
车桥	两桥底盘，高强度承载桥，引进国外先进技术设计，名牌厂家制造，性能可靠。 第一桥：单胎，转向不驱动； 第二桥：双胎，驱动不转向；	●
悬架	采用钢板弹簧悬架，承载能力强、结构简单。	●
轮胎	10.00-20	●
	10.00R20	○

制动	行车制动：脚踏板操纵的双回路气压制动。第一回路作用于后桥车轮上，第二回路作用于前桥车轮上。 驻车制动：放气制动，作用于后桥上，通过轴上的弹簧储能气室起作用。 辅助制动：发动机排气制动。	●
转向	机械式转向机构，带有液压助力	●
驾驶室	新型复合结构平头驾驶室，全封闭、装备豪华舒适。手动液压翻转，半浮悬置系统，优越的密封性、减震设计；配置大视野的前挡风安全玻璃，电控洗涤器，电子门窗升降器，带有除霜风挡的室内空气加热器，冷暖空调，收放音机等。方向盘可调节高度及角度，适合各个高度的操作人群。主副驾三点式安全带，主驾采用机械减震座椅，后排为卧铺，满足人员的操纵舒适性及乘坐方便性。	●
电气系统	直流24伏特，电池组2个 发电机：28.5±0.3伏特-70安培	●

# 技术规格

## Technical specifications

	上车	配置
<b>结构</b>	徐工设计、制造，高强度钢材制造。	●
<b>液压系统</b>	采用定量泵阀控开中心机械操纵式液压系统，起升采用定量马达，回转采用低速大扭矩柱塞马达，同时主阀集成并新增自由滑转和回转缓冲功能，阀杆采用复合节流设计微动区间设计微动更精准，回转瞬间系统压力波动小，更平顺；起升采用双泵合流，起升效率高；标配液压油散热器。	●
<b>操纵方式</b>	机械操纵。	●
<b>起升机构</b>	由液压马达驱动，内置式行星齿轮减速机和常闭式制动器，双折线卷筒，抗旋转钢丝绳。	●
<b>回转机构</b>	单排四点接触球外齿式回转支承，由液压马达驱动，内置行星齿轮减速器和常闭式制动器，可连续回转360°，具有动力控制或自由滑转的功能，可无级调速。	●
<b>变幅机构</b>	单变幅油缸，带有自补偿功能的电比例控制平衡阀。	●
<b>操纵室</b>	按人机工程学设计，外开式车门，可调式座椅。 装有安全玻璃和顶部保护栏。前窗装有遮阳板。标配风扇。 单冷空调	● ● ○
	单暖空调	○
	冷暖空调	○
<b>安全装置</b>	液压平衡阀	●
	液压溢流阀	●
	液压双向锁	●
	力矩限制器	●
	操纵杆弹簧式回中系统	●
	三圈保护器	●
	臂头设置高度限位	●
	自由滑转	●
<b>配重</b>	固定式平衡重1.05t。	●

	臂架系统	配置
<b>主臂</b>	伸缩臂采用抗扭曲设计，采用高强度结构钢制造，四节八边形截面主臂，采用单缸绳排伸缩方式。 主臂长度：9.6m~31.5m	●
<b>固定副臂</b>	三角桁架式结构，0°安装角，收存主臂旁 固定副臂长度：7m。	○
<b>臂端单滑轮</b>	单滑轮,安装在主臂顶端用于单股钢丝绳起重作业，起重性能与主臂相同，但最大起重量不超过2100kg。	●

产品各部件明细如上所述，具体部件明细请参照产品报价单

符号说明：

- —— 表示标准配置；
- —— 表示选装配置。

# 技术规格

## Technical specifications

 Chassis	Configuration
<b>Frame</b>	Designed and manufactured by XCMG, it is made of high strength steel with fully covered walking surface and anti-torsion box-typed structure. ●
<b>Outrigger</b>	H-type outrigger beam structure with 4-point supported and fully hydraulic controlled. There is an outrigger control panel installed at each side of chassis, with level gauge to level crane. Each outrigger float is stowed under each jack by using a ball joint device. The outrigger is designed to support the whole body of crane to let the crane work better under different conditions. Outrigger float diameter: φ350 mm Reaction force of outrigger at max. lifting load.....189KN ●
<b>Engine</b>	WP6.220E50, made by WEICHAI POWER, in-line, 6-cylinder, supercharging intercooling, water cooled, high pressure common rail diesel engine. Rated power of 162/2300rpm, max. torque of 850/ ( 1200-1600 ) rpm, compliant with China V emission standard. Fuel tank capacity: 200L. ●
	SC7H230Q5, made by Shanghai POWER, in-line, 6-cylinder, supercharging intercooling, water cooled, high pressure common rail diesel engine. Rated power of 170kW/2300rpm, max. torque of 900Nm/(1200-1600) rpm, compliant with China V emission standard. ○
	SC7H230Q6, made by Shanghai POWER, in-line, 6-cylinder, supercharging intercooling, water cooled, high pressure common rail diesel engine. Rated power of 170kW/2300rpm, max. torque of 900Nm/ ( 1100~1700 ) rpm , compliant with China VI emission standard. ○
<b>Transmission</b>	Mechanical transmission with synchronizers, made by Shaanxi Fast Gear Co., Ltd., 8-forward speed and 2-reverse speed. ●
<b>Axles</b>	2-axle chassis, the axles are made by a famous manufacturer with advanced foreign technology applied. ● 1st axle: single tire, for steering; 2nd axle: double-tire, for driving.
<b>Suspension</b>	also leaf springs are adopted for suspension, simple structure and strong load bearing capacity. ●
<b>Tires</b>	10.00-20 ●
	10.00R20 ○

<b>Braking</b>	Service braking: foot pedal operated double-circuit air pressure brake. 1st circuit acts on the wheels of rear axle, 2nd circuit acts on the wheels of front axles. ● Parking brake: air-release brake, acting on rear axle, it works through the spring energy storage air chamber on the axle. Auxiliary brake: engine exhaust brake.
<b>Steering</b>	Mechanically steering mechanism with hydraulic power assisted. ●
<b>Driver's cab</b>	New full-dimension enclosed cab, luxury and comfort. It is designed to be leak proof, anti-corrosive and shockproof. It is equipped with a windshield offering outstanding visibility, electric control washer, electronic lifters of doors and windows, air heater with defrosting function, heater & air conditioner, radio cassette player, etc. The height and angle of steering wheel is adjustable, suitable for operators with different statures. ● Main/auxiliary driver's seats adopt three-point contact safety belt. A mechanical seat for the driver and a simple sleeper for the co-driver's seat are installed to supply comfort and reduce fatigue.
<b>Electric system</b>	24 V DC, two sets of battery. ● Generator: 28.5±0.3 V-70 A .

# 技术规格

## Technical specifications

 Superstructure	Configuration
<b>Frame</b>	Designed and manufactured by XCMG, made of high strength steel. ●
<b>Hydraulic system</b>	Mechanical and valve controlled hydraulic system with fixed displacement pump is adopted. Winch adopts fixed displacement motor. Low-speed large torque slewing system is adopted. Main valve also has the function of free sliding and slewing buffering. Multi-throttle design is adopted for valve rod with better inching control. Pressure fluctuation of slewing system is flat during the operation and slewing control is smooth. Double-pump confluence technology is applied for winch system, high lifting efficiency and standard hydraulic radiator. ●
<b>Operating mode</b>	Mechanical control ●
<b>Winch system</b>	Driven by a hydraulic motor, with built-in planetary gear reducer and constant closed brake fitted. Drum with Lebus-type grooving and rotation-resistant wire rope. ●
<b>Slewing system</b>	A single-row, four-point contact-ball external slewing bearing is driven by hydraulic motor, with built-in planetary gear reducer and constant-closed brake equipped, and may continuously slew 360°. Power control and free slewing function as well as stepless speed regulation are available. ●
<b>Elevating system</b>	Single cylinder with self-compensation electric-proportional balanced valve. ●
<b>Operator's cab</b>	Operator's cab is designed according to ergonomics with outward-open door and adjustable seat. ● It is equipped with safe glass and roof protective grille. Windshield is equipped with sun visor. Fan is standard. Air conditioner ○ Heater ○ Heater and air conditioner ○
<b>Safety devices</b>	Hydraulic balance valve ● Hydraulic relief valve ● Double-way hydraulic valve ● Load moment limiter; ● Spring centering system for control levers ● (Lowering limiter) ● Anti-two block at boom head ● Free slewing, ●
<b>Fixed counterweight</b>	The weight of fixed counterweight is 1.05t. ●

 Boom system	Configuration
<b>Boom</b>	Octagon boom is made of high strength steel, with special anti-deformation design. ● Single cylinder plus ropes is used to telescope the boom. Boom length: 9.6m ~ 31.5m
<b>Fixed jib</b>	Triangle lattice structure, 0° jib offset angle, stowed at the side of main boom. ○ Fixed jib length: 7m.
<b>Single top</b>	Installed at the boom top, used for single line operation. Its lifting performance is the same as that for boom, but the max. lifting load could not exceed 2100kg. ●

**Product parts list is as mentioned above. Please refer to the product quotation for specific parts.**

**Symbol explanation:**

- —it means the standard configuration;
- —it means the optional configuration.

## 重量 Weight





车桥 Axle	1	2	总重量 Total weight
t	6	11.1/11.4 (国六 China VI emission standard)	17.1/17.4 (国六 China VI emission standard)







吊钩 Hook	倍率 No. of lines	吊钩重量 Weight kg	吊钩尺寸 Dimensions mm	备注 Remarks
12t	6	145	1002×410×242	单钩 Single hook, 标配 Standard
2.1t	1	60	518×236×236	单钩 Single hook, 标配 Standard

## 作业速度 Working speeds



		
10.00-20	2 ~ 90 km/h	41%



作业机构 Drive	作业速度 Working speed	最大单绳拉力 Max. single line pull	钢丝绳直径/长度 Rope diameter/ length
	0-130 m/min, 单绳, 第四层 m/min, single line, 4th layer	23kN	12 mm/140 m
	0-130 m/min, 单绳, 第四层 m/min, single line, 4th layer	23kN	12 mm/85 m(选装副臂) 12 mm/71 m(不选装副臂)
	0-3 r/min		
	从-2°抬起至80°约38s Approx. 38s for boom elevation from -2° to 80°		
	从9.6m伸出至31.5m约58s Approx. 58s for boom extension from 9.6m to 31.5m		



## 臂架组合方案

### Boom / Jib combinations

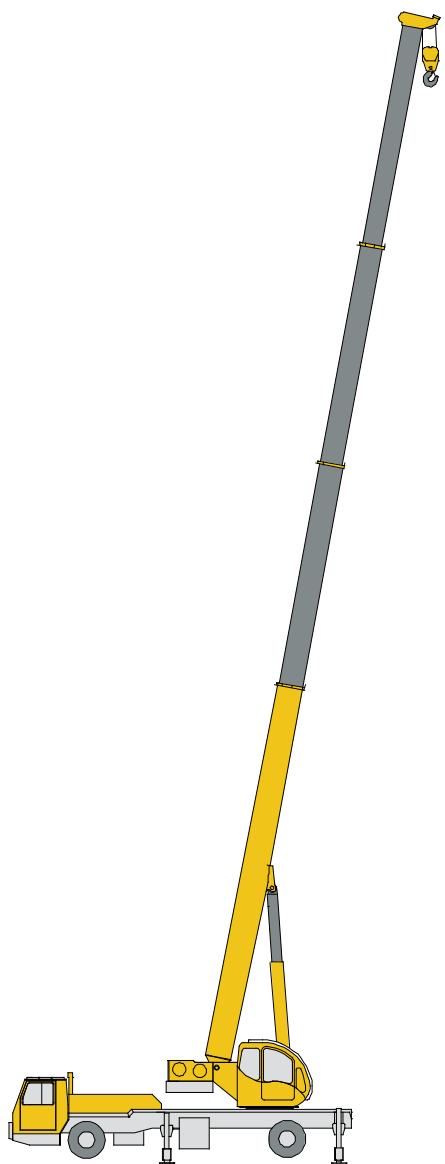

主臂  
Telescopic boom

T : 9.6-31.5m

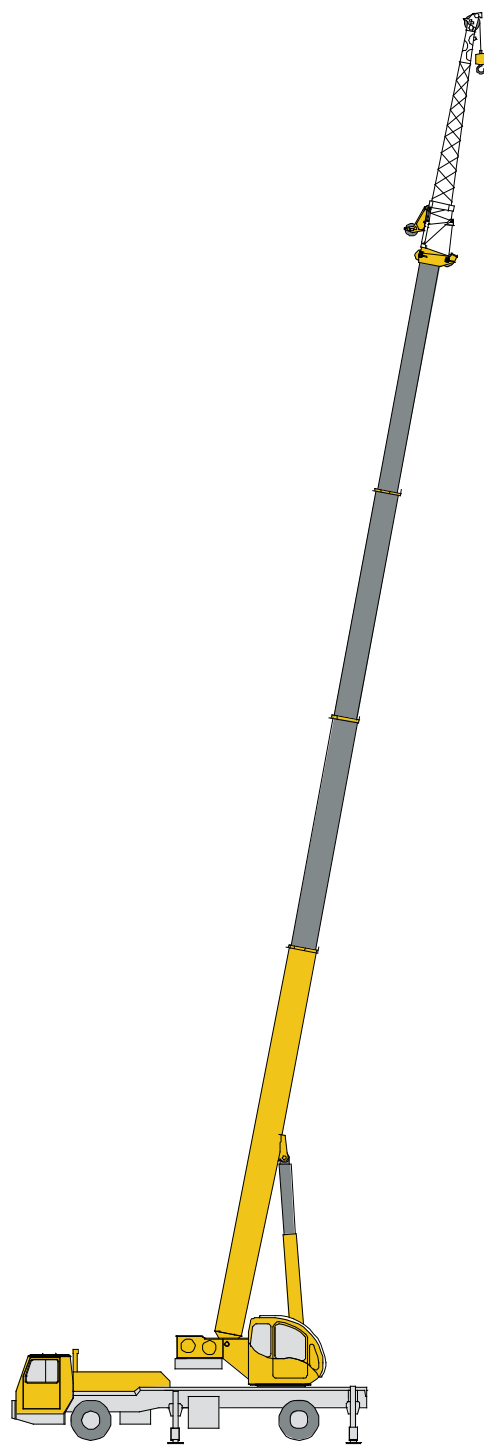

副臂  
Jib

T : 31.5m  
J : 7 m

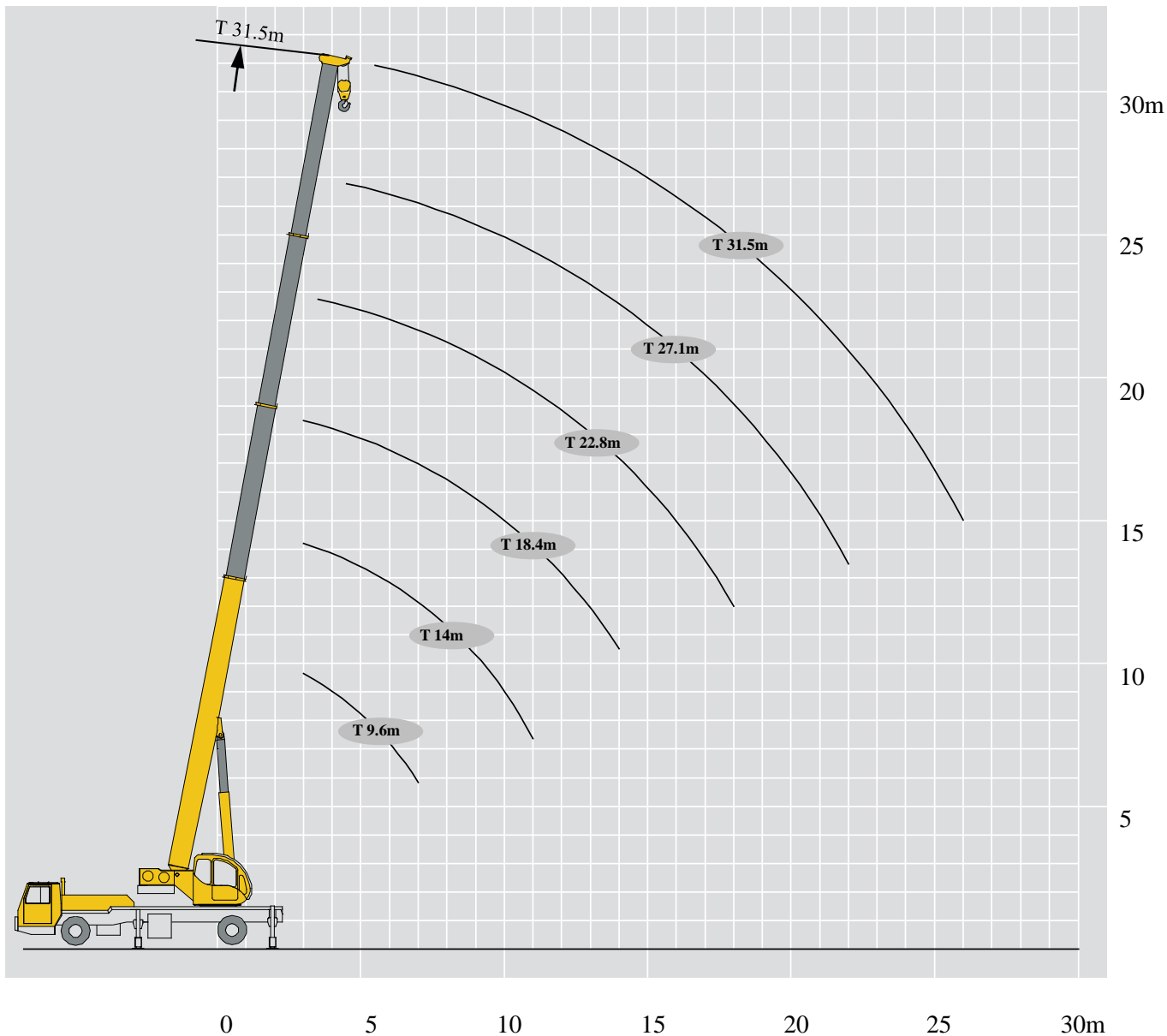

# 起升高度曲线图 Lifting heights

副臂  
Jib

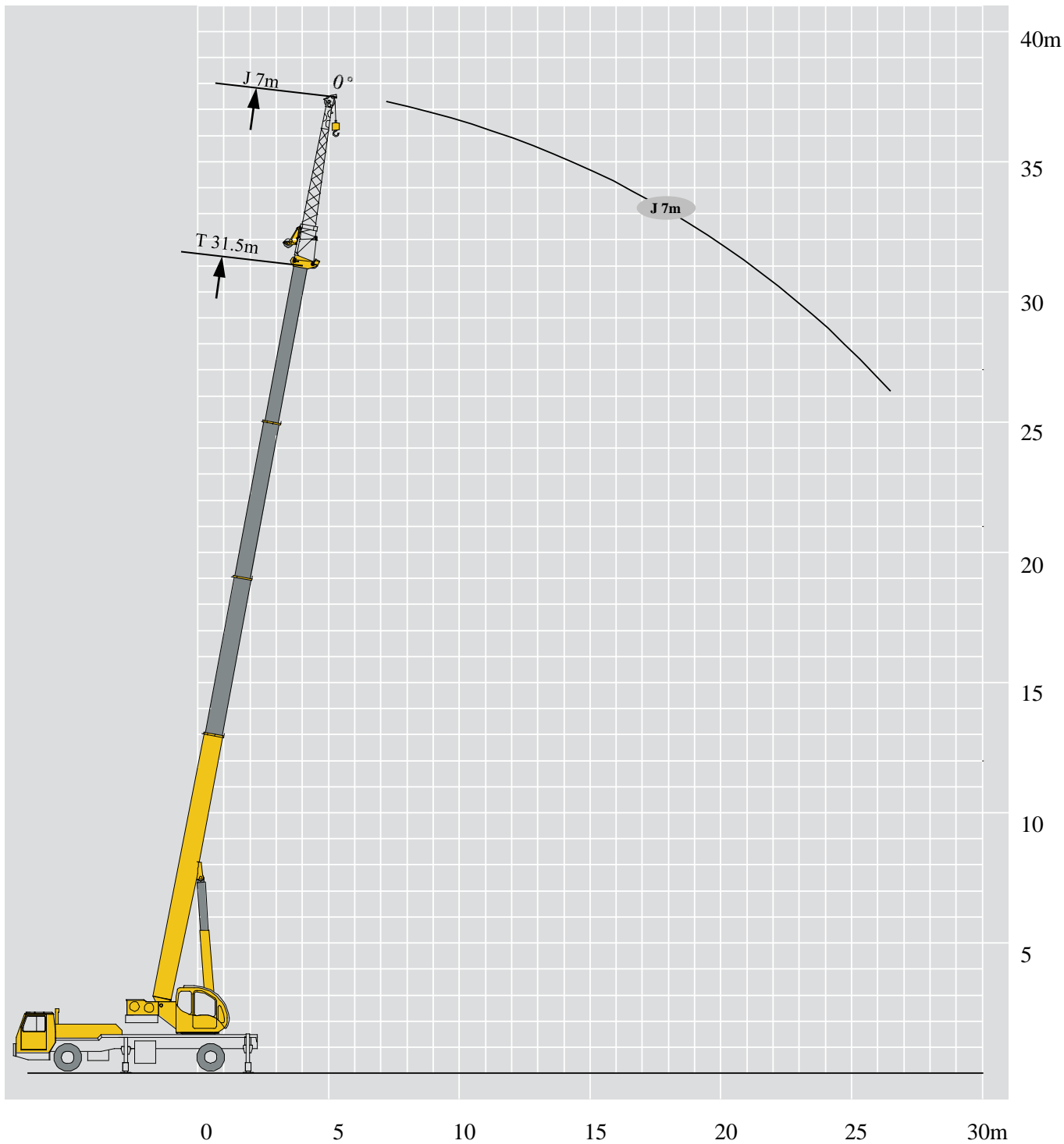

# 起重性能表

## Lifting capacities

T 9.6~31.5m

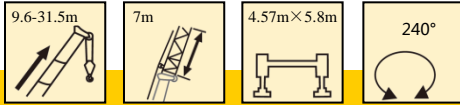













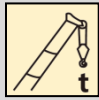

	9.6m	14m	18.4m	22.8m	27.1m	31.5 m	31.5+7 m	
3	16000	10600	9600					3
3.5	16000	10600	9400	7900				3.5
4	11500	10500	9200	7500				4
4.5	11000	10200	8900	7100	5200			4.5
5	10100	9800	8600	6700	5200			5
5.5	9000	8900	8300	6300	5200	4200		5.5
6	8100	8100	7800	6000	4900	4200		6
6.5	7300	7400	7300	5700	4600	4000		6.5
7	6500	6700	6800	5300	4400	3800	2100	7
8		5400	5600	4800	3900	3500	2100	8
9		4400	4600	4400	3500	3100	2100	9
10		3700	3800	3800	3200	2800	1900	10
11		3200	3200	3300	2900	2500	1800	11
12			2800	2800	2600	2300	1650	12
14			2100	2100	2200	2100	1200	14
16				1700	1700	1600	1100	16
18				1300	1300	1400	900	18
20					1000	1100	750	20
22					800	800	550	22
24						600	350	24
26						500	300	26

# 符号标识

## Description of symbols

### 常规标识

#### General symbols

	上车 Superstructure		底盘 Chassis
	起重能力 lifting capacity		车桥 Axle
	吊臂长度 Boom length		行驶速度 Driving speed
	工作幅度 Radius		爬坡能力 Gradability
	吊臂仰角 Boom position		轮胎 Tyres
	固定副臂长度 Fixed jib length		支腿 Outriggers
	吊钩 Hook block		240°回转 ( 侧后方作业 ) 240° rotation ( Over side or over rear operation )
	卷扬 Winch		

# 主要技术参数表

## Transportation plan

类别 Category	项目 Item	单位 Unit	参数 Parameter		
尺寸参数 Dimensions	外形尺寸 (长×宽×高) Outline size (lengthch×width×height)	mm	11560×2500×3440		
	轴距 Wheel base	mm	4700		
	轮距 (前/后) Track (Front/ Rear)	mm	美驰：2076/1830 汉德：2048/1830		
	前悬/后悬 Front/ Rear overhang	mm	1450/2455		
	前伸/后伸 Front/ Rear extension	mm	2505/435		
重量参数 Weight	最大允许总质量 Max. permissible total weight	kg	17100		
	轴荷	一轴 1st axle	kg	6000	
		二轴 2nd axle	kg	11100	
动力参数 Power	发动机型号 Engine model	—	SC7H230Q5	WP6.220E50	SC7H230Q6
	额定功率/转速 Engine rated power/rpm	kW/(r/min)	170/2300	162/2300	170/2300
	最大净功率/转速 Max. net power/rpm	kW/(r/min)	166/2300	158/2300	168/2300
	最大输出扭矩/转速 Engine rated torque/rpm	N.m/(r/min)	900/1200-1600	850/1200-1600	900/1100~1700
行驶参数 Travel	最高车速 Max. travel speed	km/h	90		
	最低稳定车速 Min. travel speed	km/h	2~3		
	最小转弯直径 Min. turning diameter	m	≤18		
	臂头最小转弯直径 Min. turning diameter at boom tip	m	≤22.8		
	最小离地间隙 Min. ground clearance	mm	250		
	接近角 Approach angle	°	21		
	离去角 Departure angle	°	13		
	制动距离 (制动初速度为30km/h) Braking distance (at 30 km/h)	m	≤10		
	最大爬坡能力 Max. grade ability	%	≥41		
	百公里油耗 Fuel consumption per 100 km	L	20		
噪音 Noise	加速行驶机外噪声 Exterior noise level	dB(A)	≤84		
	驾驶员耳旁噪声 Noise level at seated position	dB(A)	≤90		

# 主要技术参数表

## Transportation plan

类别 Category	项目 Item		单位 Unit	参数 Parameter	
主要性能参数 Main performance	最大额定总起重量 Max. total rated lifting capacity		t	12	
	最小额定工作幅度 Min. rated working radius		m	3	
	转台尾部回转半径 Turning radius at turntable tail		mm	2950	
	最大起重力矩 Max. load moment	基本臂 Base boom		kN.m	495
		最长主臂 Fully-extended boom		kN.m	288
		最长主臂+副臂		kN.m	198
	支腿跨距 Outrigger span	纵向 Longitudinal		m	4.57
		横向 Lateral		m	5.8
	起升高度 Hoist height	基本臂 Base boom		m	9.6
		最长主臂 Fully-extended boom		m	31.8
		最长主臂+副臂		m	39
	起重臂长度 Boom length	基本臂 Base boom		m	9.6
		最长主臂 Fully-extended boom		m	31.5
最长主臂+副臂		m	31.5+7		
副臂安装角 Jib offset angle			°	0	
工作速度参数 Working speed	起重臂起臂时间 Boom raising time		s	≤38	
	起重臂全伸时间 Boom fully extended time		s	≤58	
	最大回转速度 Max. slewing speed		r/min	3	
	支腿收放时间 Outrigger extending and retracting time	水平支腿 Outrigger beam	收 Retracting	s	≤15
			放 Extending	s	≤20
		垂直支腿 Outrigger jack	收 Retracting	s	≤20
			放 Extending	s	≤25
	起升速度 (单绳,第四层,空载) Hoisting speed (single line, 4th layer, no load)	主起升机构 Main winch		m/min	≥135
副起升机构		m/min	≥135		
噪声 Noise	机外辐射 Exterior noise level		dB ( A )	≤122	
	司机位置处 Noise level at seated position		dB ( A )	≤90	

## 注意事项

### Notes

1. 表中额定总起重量值，是在平整的坚固地面上本起重机能够保证的最大总起重量，包括吊钩和吊具的重量，所以为了估算重物重量，必须减去上述的装置重量。
2. 表中的工作幅度为起吊重物离地时起重物到起重机回转轴线的水平距离，是包括起重臂变形量在内的实际值，因而起吊前应考虑起重臂变形量。
3. 只允许在5级(瞬时风速14.1m/s，风压125N/m<sup>2</sup>)风以下进行作业。
4. 吊重前操作者必须对物体的重量和工作范围了解后选择合适的作业工况，严禁超出表中的数值。幅度及臂长在相邻两个数值之间时，应依据两个数值中较小值确定起重作业。
5. 应按主臂仰角范围作业，即使是空载，也不应使主臂仰角处于范围外，谨防整机倾翻。
6. 表中的主臂长度应要按照每节臂的伸缩要求进行伸出。

1. The total rated loads given in the rated load charts are the maximum lifting capacity when the crane is set up on firm and level ground, which includes the weight of the hook block and slings. The weight of above-mentioned devices should be deducted to correctly calculate the load weight.
2. The working radius shown in the rated load charts is the radius when the load is lifted off the ground, and it is the actual value including loaded boom deflection.
3. A lifting operation is permissible only when the wind force is below grade 5 (instantaneous wind speed is 14.1 m/s, wind pressure is 125 N/m<sup>2</sup>).
4. Before beginning lifting operation, the operator should know the weight of the load to be lifted and its working range, and then select proper working conditions. Never operate the crane beyond the limit shown in the chart. Use the lower value from the chart when the boom length or working radius is between the range of values.
5. Observe the boom angle limit. Never operate the crane with the boom angle beyond the recommended limit even if a load is not being carried. Otherwise, the crane will tip.
6. The boom length given in the rated load charts should accord with the telescoping code of boom sections .